



Aktivated Carbon Filtercartridges

Filterinformation

Sorb activated carbon cartridges are pressed and extruded under high pressure to prevent carbon particles passing into the filtrate. Sorb have an excellent adsorption characteristics for chlorine and organic compounds.

Applications

Potable water, spirits, water based and organic solvents for removal of color, smell taste contamination. Galvanic baths, removal of organic contamination from nickel and copper baths, through anodic oxidation or cathodic reduction



Type 01 - 04

Type 02

Filterinformatie

Sorb actieve kool cartridges zijn geperst en geëxtrudeerd onder hoge druk om afgifte van koolstof particles in het filtraat te voorkomen. Sorb cartridges hebben een uitstekende adsorptie karakteristiek voor chloor en organische verbindingen.

Toepassingen

Drinkbaar water, sterke dranken, water gebaseerd en organische oplosmiddelen voor het verwijderen van kleur, geur smaak besmetting. Galvanische baden, verwijdering van organische vervuiling van nikkel en koper baden, door middel van anodische oxidatie of kathodische reductie





Technical Data:	Type 01 (04)	Type 02
Filter Fineness:	1, 5 and 10 µm	5 µm
Efficiency:	95 %	95 %
Length:	4 7/8, 9 3/4, 20 and 30"	5, 9 3/4, 10, 20 and 30"
Inside Diameter:	26 mm (01), 28 mm (04)	27 mm
Outside Diameter:	71 mm (01), 110 mm (04)	65 mm
Gaskets:	ENGAGE (Ethylene-octene copolymer)	Polypropylene
Max. Working Temperature:	52°C	52°C
Max. Differential Pressure:	7 bar	2.5 bar
Recommended Flow Rate (max.):	8 l/min per 9 3/4" length	8 l/min per 9 3/4" length
Activated Carbon:	85-90% coconut shell, 10-15% others	85-90% coconut shell, 10-15% others
Weight of Carbon:	4 7/8" = 180 g 9 3/4" = 360 g (type 04 = 1100 g) 20" = 720 g (type 04 = 2200 g) 30" = 1080 g	5" = 95 g 9 3/4 + 10" = 190 g 20" = 380 g 30" = 570 g
Binder:	HDPE	HDPE
Outside:	Polypropylene fleece and net	washed Polypropylene yarn

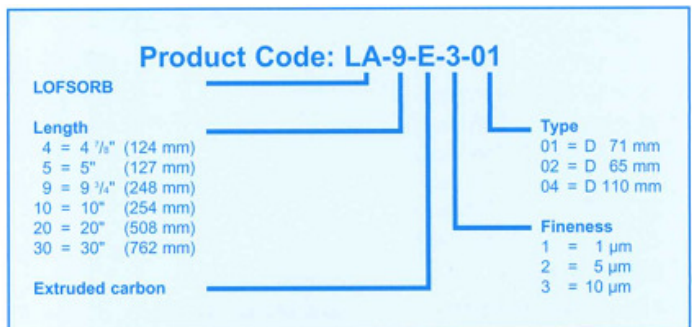
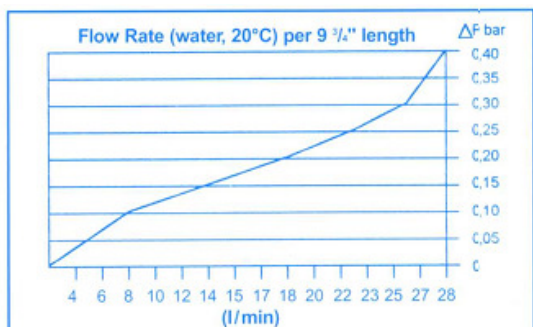

Please note: Due to the outside diameter of 71 mm, SORB series 01 will not fit into the standard housing of the TOPCART series (from TKF-609 up). Special constructions are available upon request.